



ERGATTA

ASSEMBLY MANUAL

For step-by-step video instruction, watch the assembly video at
<https://erga.io/rower-assembly>

MAIN PARTS

- A** Rail x2*
- B** Tablet
- C** Rear Spacer* with Bungee
- D** Seat
- E** Footboard*
- F** Tank Assembly & Mounting Arm

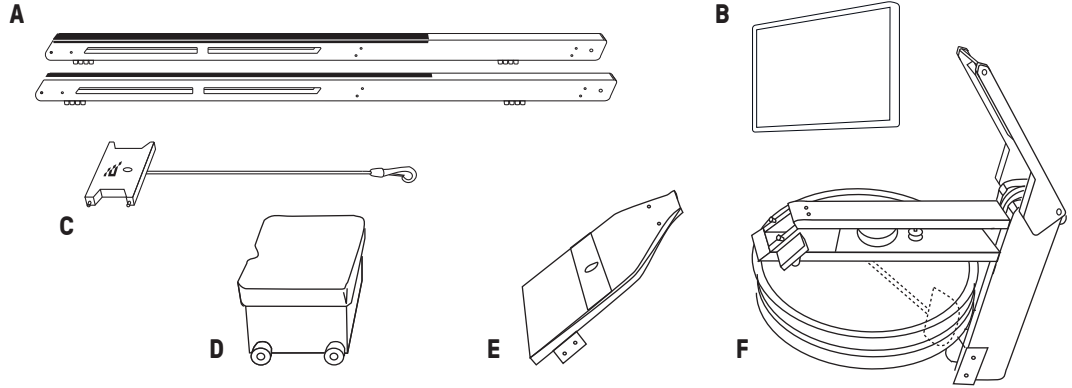

OTHER PARTS

- G** Dolly Wheel Assembly x 2
- H** JC Bolt x 8
- I** JC Nut x 12 (4 are pre-installed on Rear Spacer)
- J** Handle Rest x 2
- K** Handle Rest Bolt x 2
- L** 5mm Allen Key x 2
- M** Footpads x 2
- N** Syphon Pump x 1
- O** Tablet Bolt x1
- P** Power Cord x1
- Q** USB Cable x1
- R** Pin Cable x1
- S** Connector Cable x1

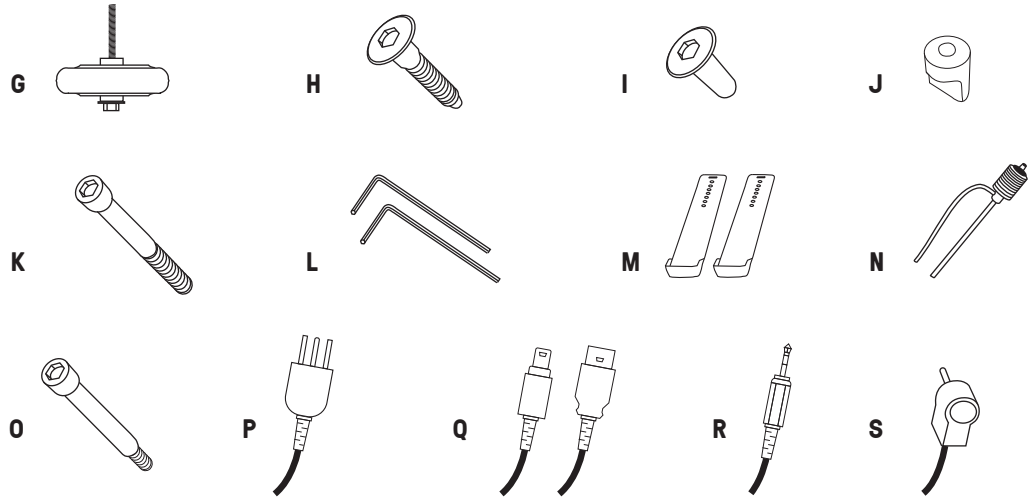

1

Lay the rails on the floor parallel to one another. Make sure that the black extrusions are facing the inside of the rails.



2

Position the rear spacer so that the logo is facing up and the bolt with the bungee cord is facing down. Unscrew the JCN nuts from the rear spacer.

JCN Nut
(x4)

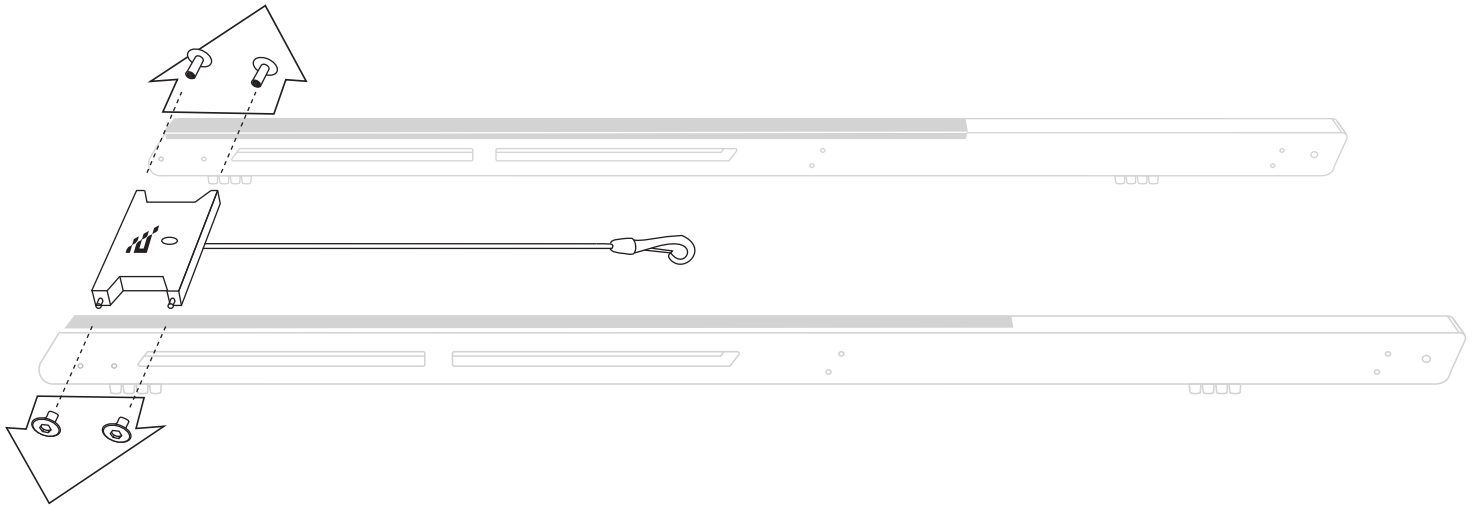

3

Connect the rear spacer to the rails.

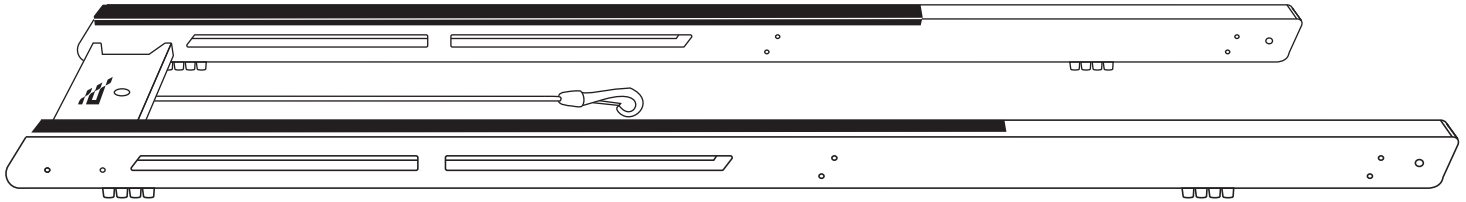

4

Screw the JCN nuts back into the side of the rails. Use the 5mm Allen key to tighten.

JCN Nut
(x4)



Allen Keys

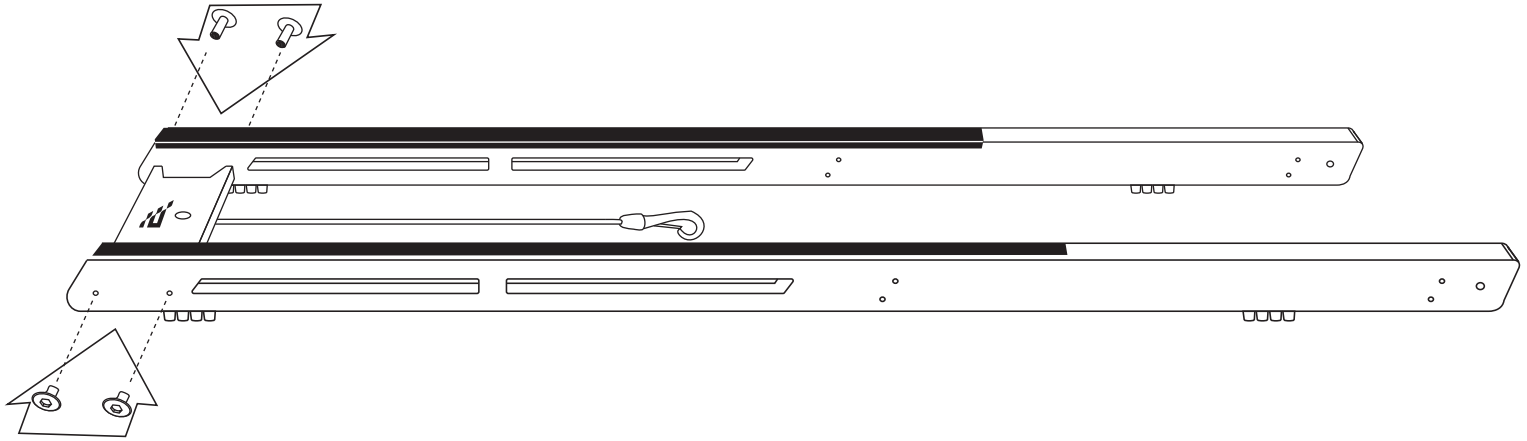
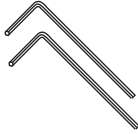

5

Place the seat assembly between the rails. The indent on the seat should face the rear spacer. Note: it may be necessary to separate the rails slightly to fit.

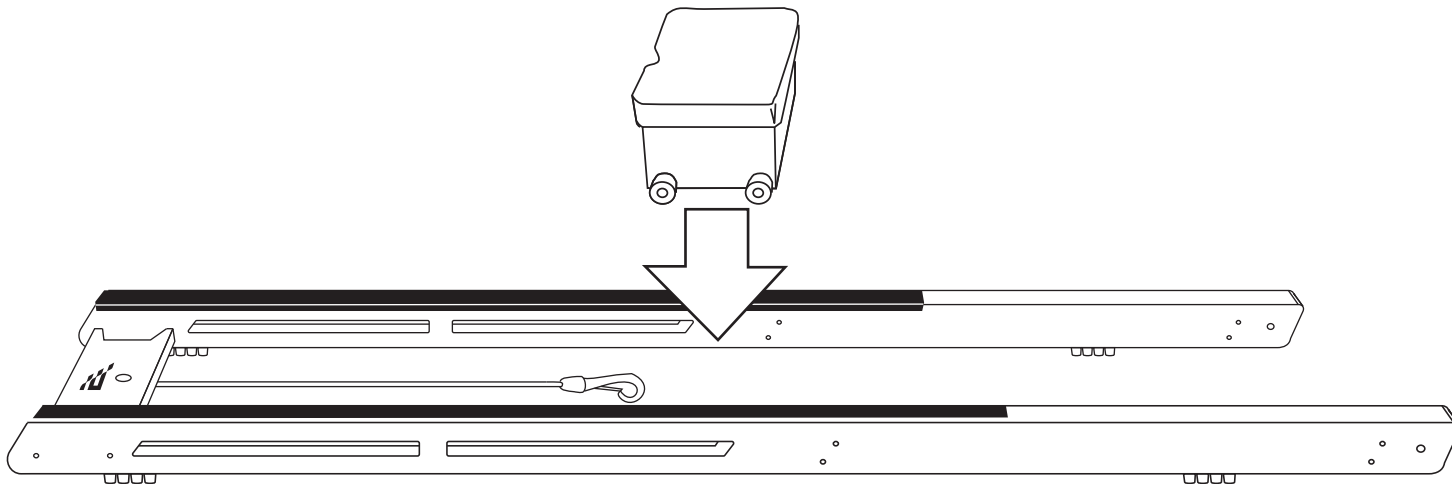

6

Unscrew the wheel assembly and attach the wheels to the outside of the rails. Screw in the wheels using your hands, then use the 5mm Allen key to tighten.

JCN Nut
(x2)



Wheel Assembly
(x2)

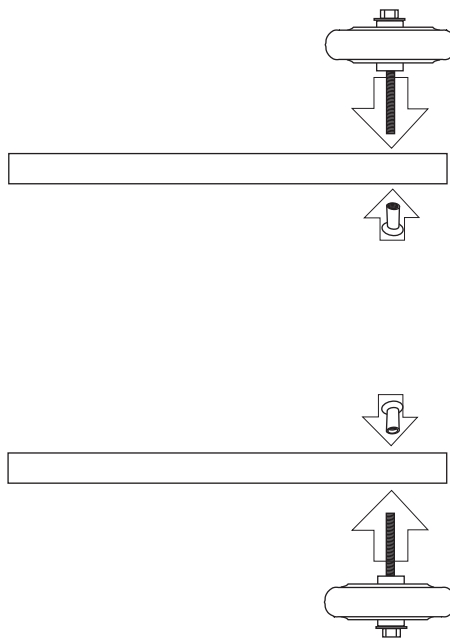
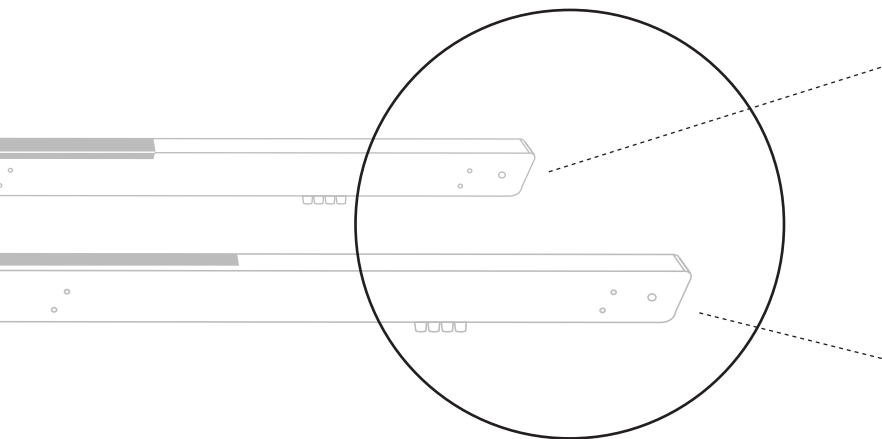
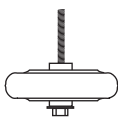

7

Place the tank assembly between the rails. Using the JCN nuts and JCB bolts, attach the tank to the rails. Use the 5mm Allen keys to screw and tighten.

**JCN Nut
(x4)**



**JCB Bolt
(x4)**

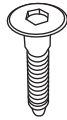

Allen Keys

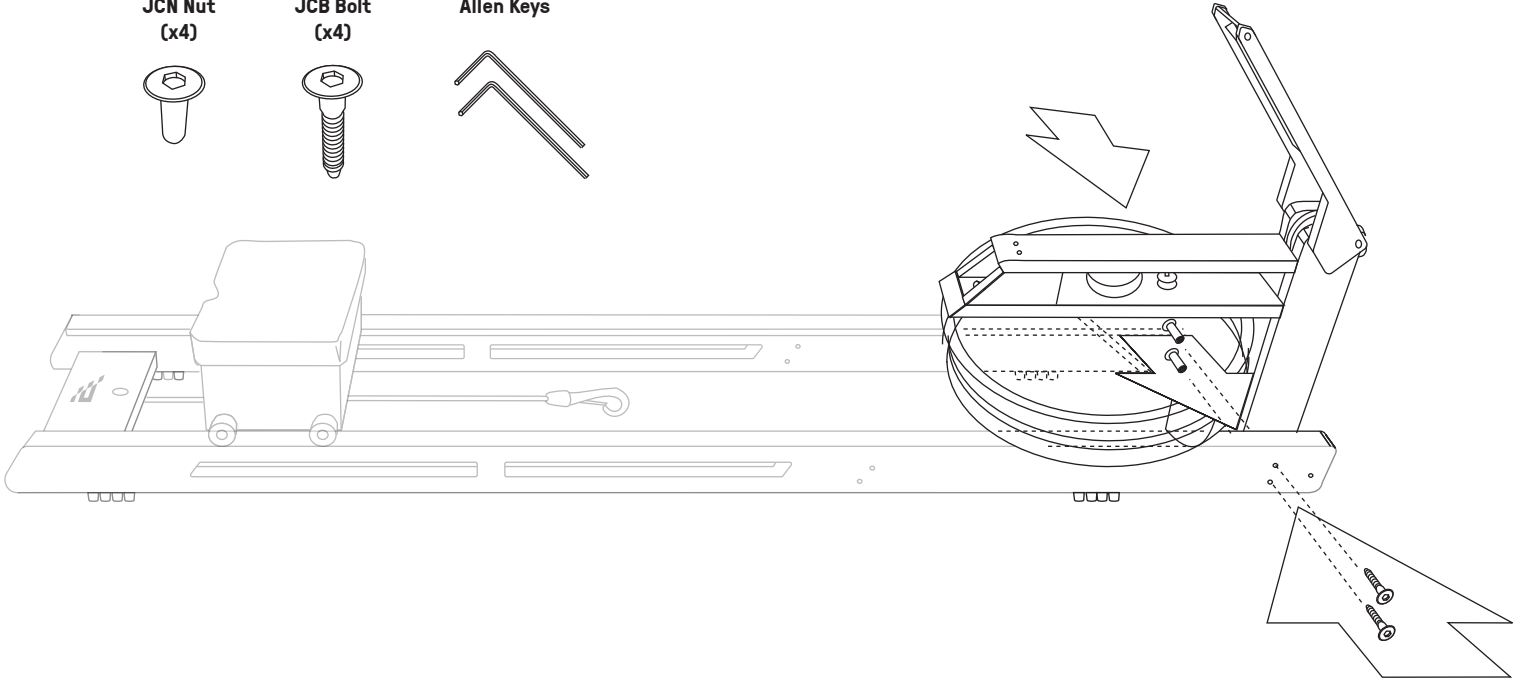
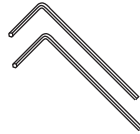

8

Place the tank assembly between the rails. Using the JCN nuts and JCB bolts, attach the tank to the rails. Use the 5mm Allen keys to screw and tighten.

JCN Nut
(x4)



JCB Bolt
(x4)

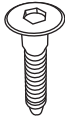

Allen Keys

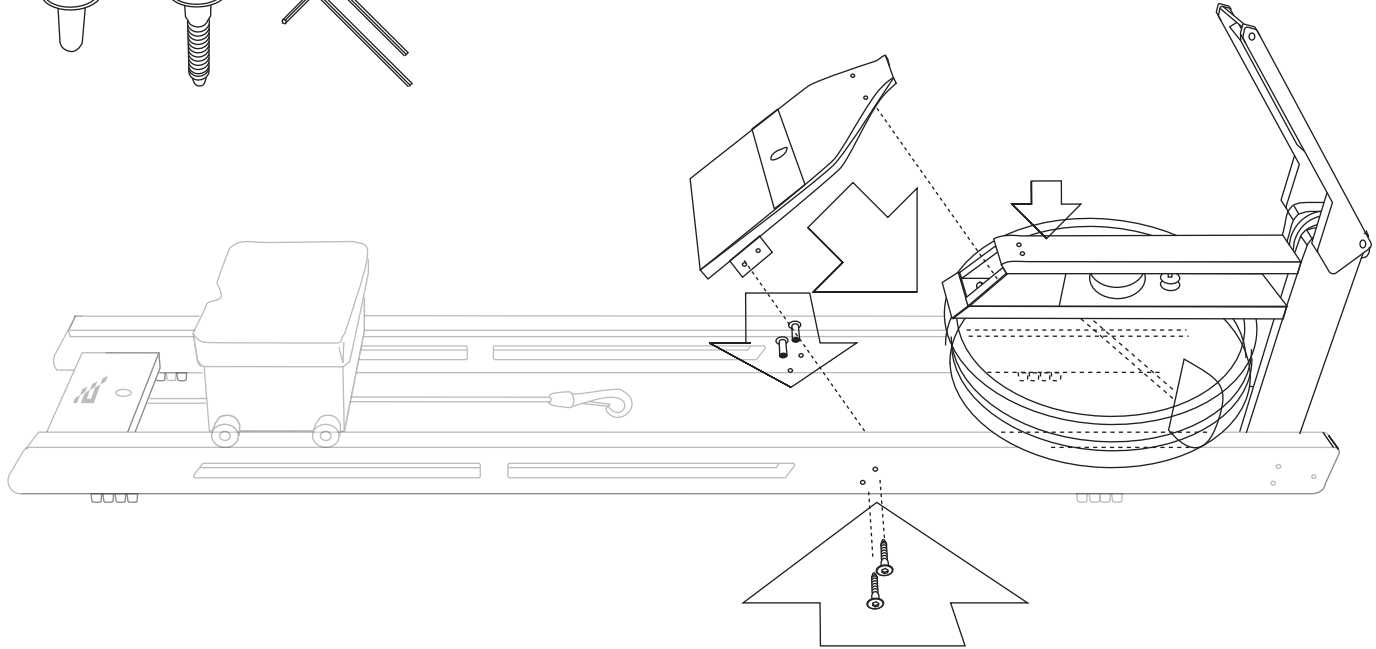
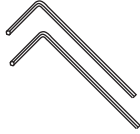

9

Press and hold the heel adjustment button to add the footpads.

Footpads
(x2)

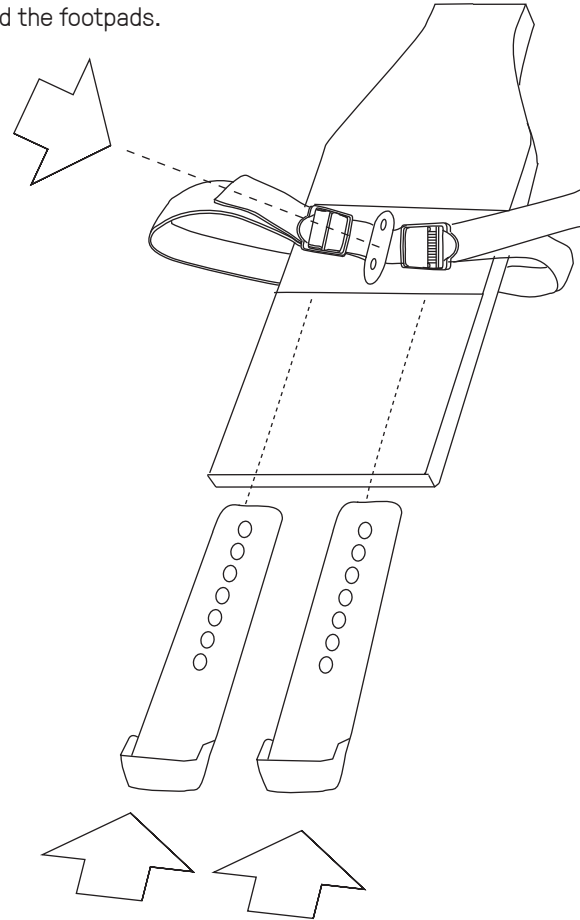
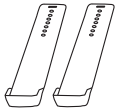

10

Screw the handle rests into position using the handle rest bolts. Do not overtighten.

Handle Rest Bolt
(x2)



Handle Rests
(x2)

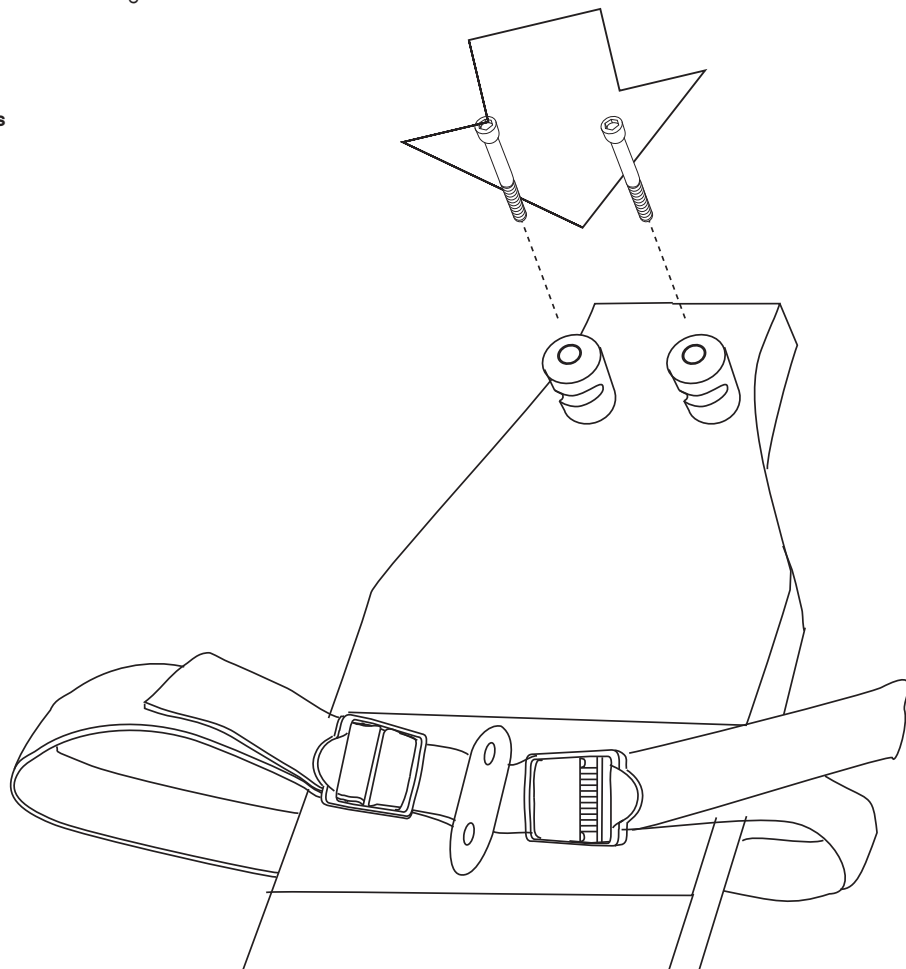

11

Stand the machine upright. Release the recoil belt and connect the bunjee to the recoil strap.

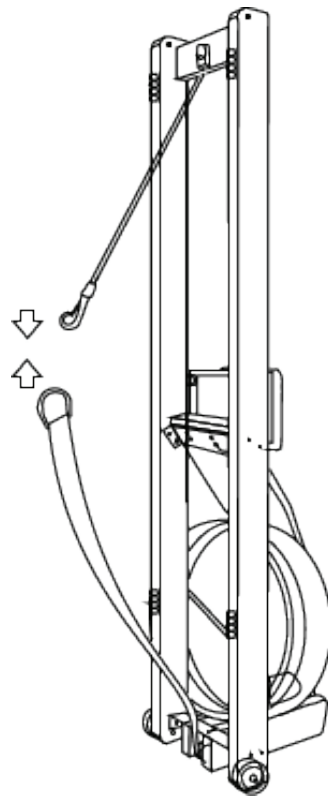
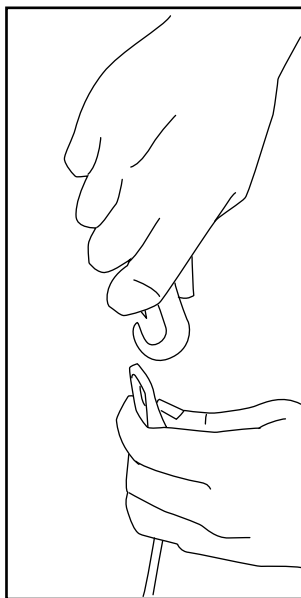
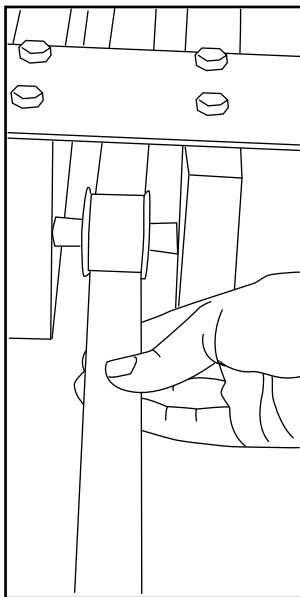
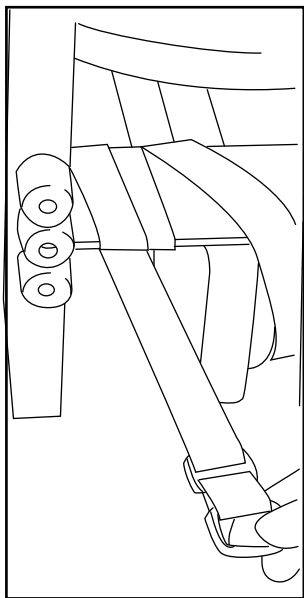

12

Fill a separate tank with water. Using the siphon, fill the water tank with water to the level 17 marker on the side of the tank. Add a purification tablet (provided in your Ergatta bag).

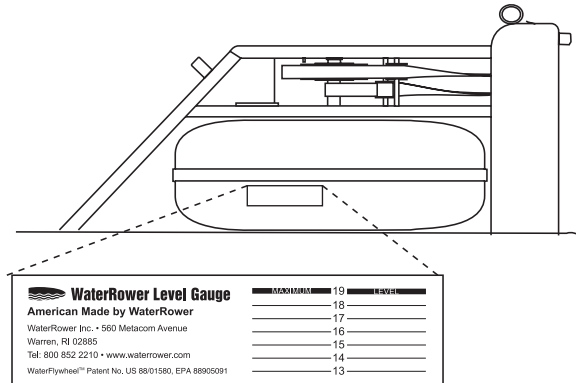
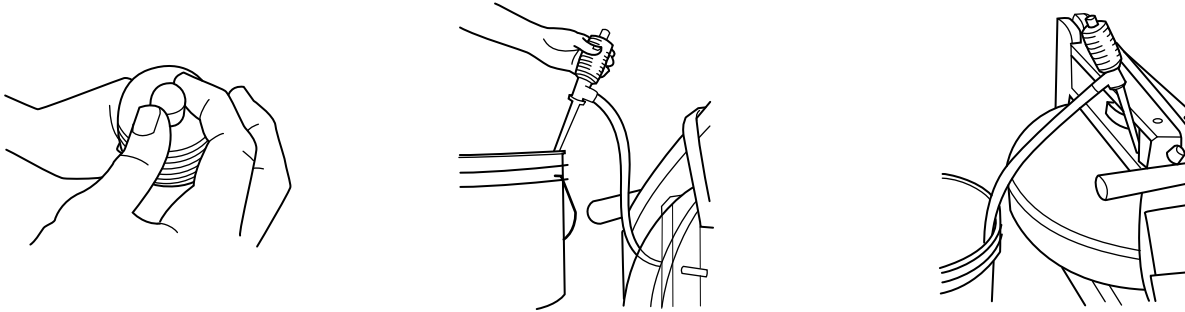

13

Raise the mounting arm, gently pull the spring lock on the back of the forward riser, and raise the arm until it locks in place.

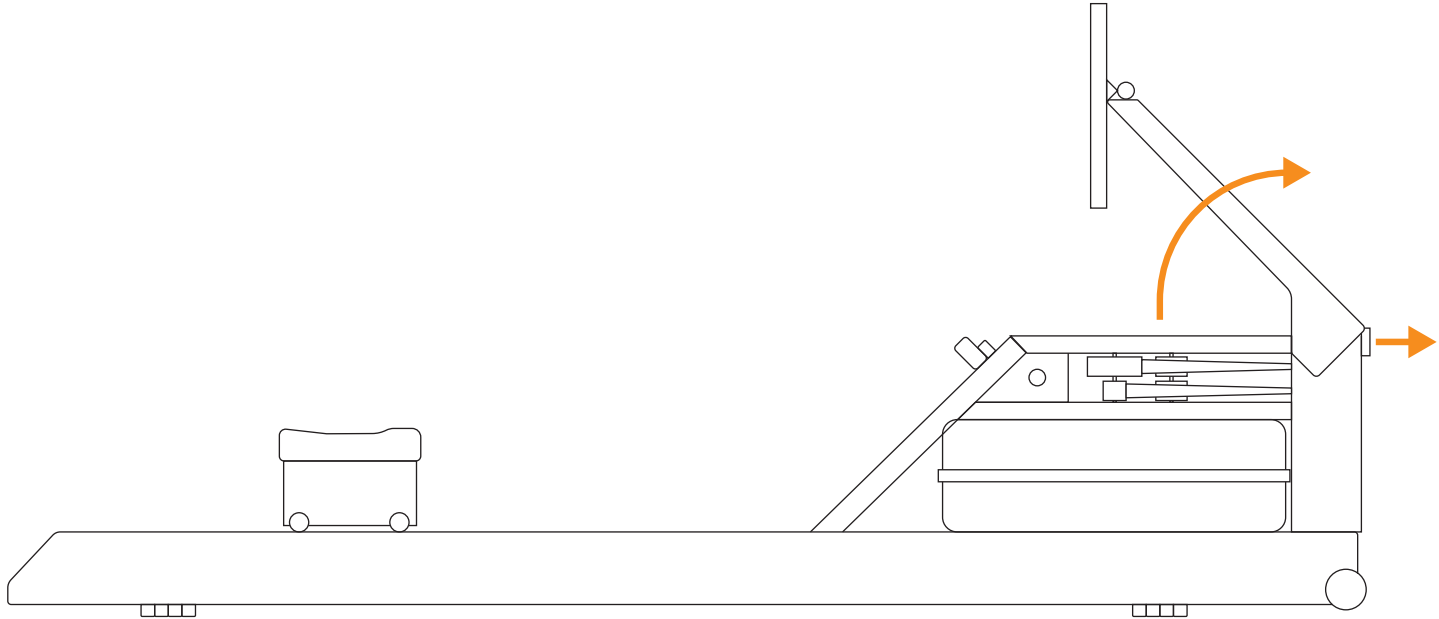

15

Assemble the wires.

